



AUTOPLY

AUTOMOTIVE INSULATION KITS



- › Part numbers are printed on adhesive release paper.
- › The release paper backing is pre-seamed for easy peel-and-stick application.
- › Ensure surfaces are clean, dry, and free from dirt, dust, or loose residue to allow proper adhesion.
- › This product can withstand installed temperatures of -40°F to 250°F.

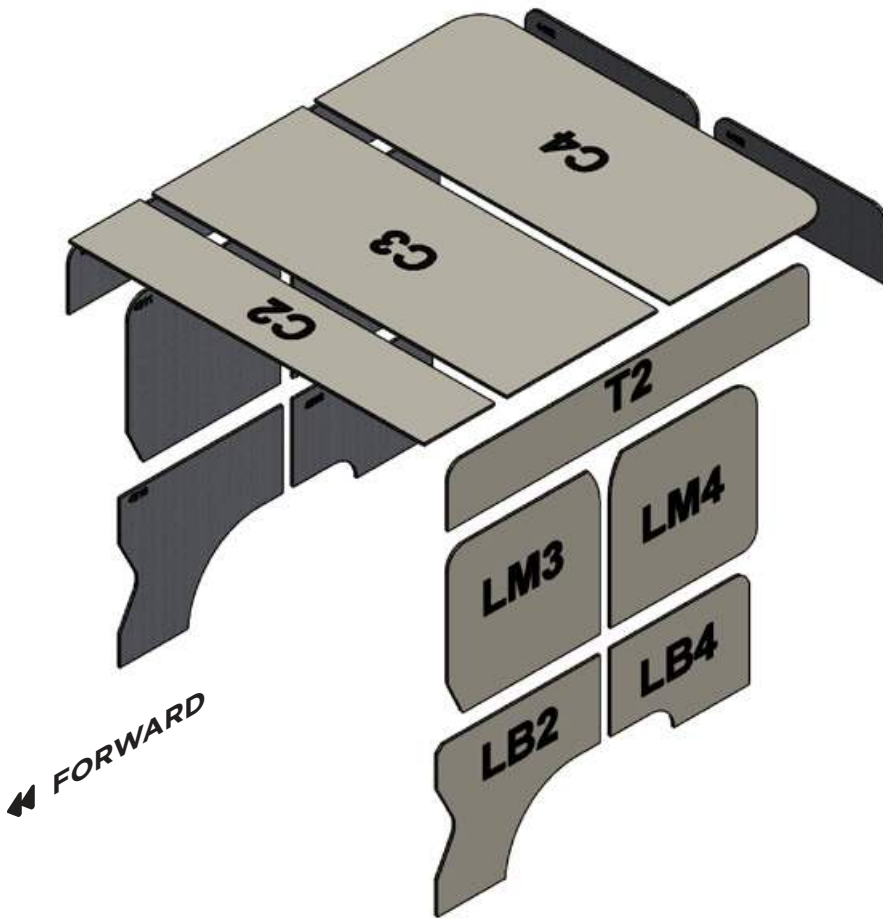

LEFT (DRIVER) SIDE

NOTE: Flip sheet over to view opposite side.

Each part is labeled with a printed alphanumeric code that indicates its specific location and position on the vehicle.

C = ceiling	L = left side	R = right side
M = mid-section	B = bottom	RD = rear door

RAM PROMASTER

136 High Roof Crew Van

Model years: 2016 - present

PRE-CUT INSULATION KIT WITH SELF-ADHESIVE

KIT PART NUMBERS

4136C, 4136C-1

CONTENTS

Ceiling and sides.
15 pieces.

i Installation Tip

For larger pieces, start by peeling back a small section of adhesive on one end. Position the piece in place, then gradually remove the rest of the release paper while pressing it down from side to side.

 www.autoply.net

 +1 (954) 799-3035

 info@autoply.net



AUTOPLY
AUTOMOTIVE INSULATION KITS



RAM PROMASTER

136 High Roof Crew Van
Model years: 2016 - present

PRE-CUT INSULATION KIT WITH SELF-ADHESIVE

KIT PART NUMBERS

4136C, 4136C-1

CONTENTS

Ceiling and sides.
15 pieces.

i Installation Tip

For larger pieces, start by peeling back a small section of adhesive on one end. Position the piece in place, then gradually remove the rest of the release paper while pressing it down from side to side.

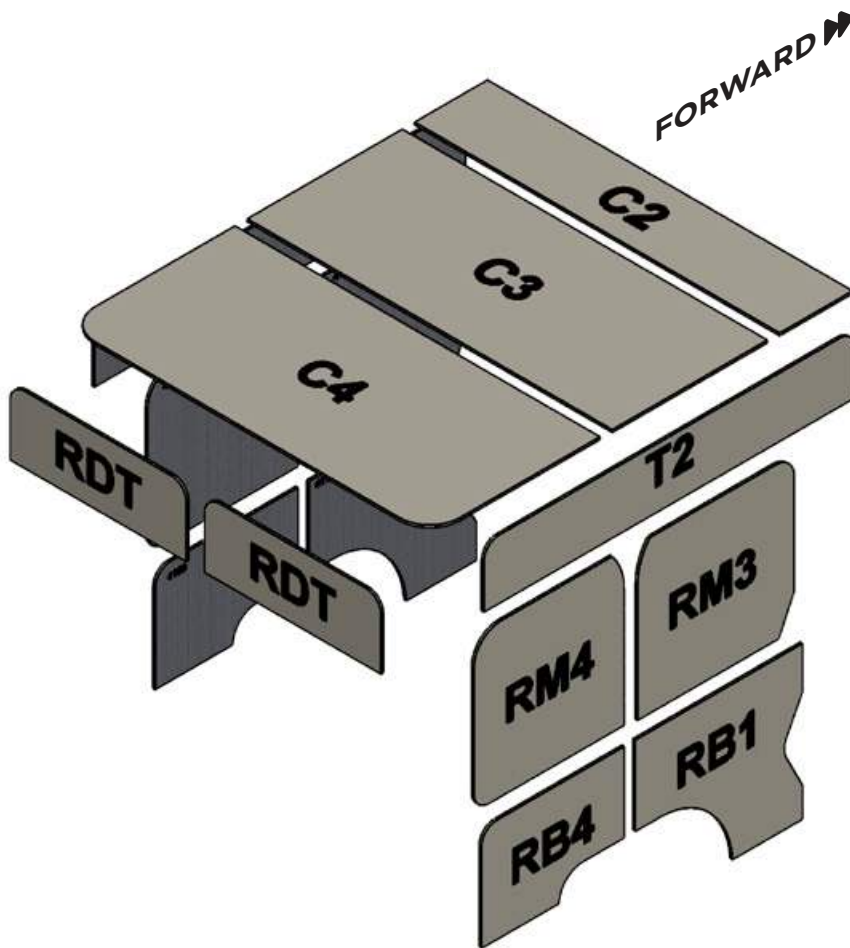

RIGHT (PASSENGER) SIDE

NOTE: Flip sheet over to view opposite side.

Each part is labeled with a printed alphanumeric code that indicates its specific location and position on the vehicle.

C = ceiling **L** = left side **R** = right side
M = mid-section **B** = bottom **RD** = rear door

 www.autoply.net

 +1 (954) 799-3035

 info@autoply.net